

S5000 AWTS with Equalisation Tank

TECHNICAL DATA SHEET

- The S5000 Aerated Wastewater Treatment System (AWTS) turns wastewater into clear, odourless, water for pumped disposal to vegetation for transpiration to the atmosphere.
- Reliable, high quality, Australian designed and built, all concrete treatment system.
- Particularly suited for commercial premises with dynamic flows.
- Dynamic flows are retained in the equalization chamber and pulse dosed into the treatment process. This prevents overloading and ensures consistent maximum treatment.
- It is a modular unit, allowing the treatment system to be expanded if required.

SPECIFICATIONS

COMPONENT	DESCRIPTION
Septic tank	Septic chamber 4600L. Equalisation chamber 2350L
Dosing air lift pump	1 x 80l/min diaphragm air blower 240vac
Treatment tank	70250L consisting of: Three discrete aeration chambers – 2174L, 1081L 1200L
Aeration	1 x 200l/min diaphragm air blower 240vac 170 - 190 watts 10 air diffusers
Bacterial support media	2.163m ³ providing 437m ² of surface area
Clarifiers	Primary clarifier Surface area 0.727m ² Secondary clarifier surface area 0.50m ² Waste activated sludge recycled to the septic tank
Disposal/transfer pump	Drainer type. 240vac, 7 amps, 0.75kW
Control box	Plugs into a 3 pin outlet - 10 amps circuit

FEATURES

- ✓ 30 Year Warranty - concrete components
- ✓ 2 Year Conditional Warranty - Pumps and Blowers
- ✓ Alarm System
- ✓ Chlorine Disinfection
- ✓ 1st Year Servicing, if required
- ✓ Includes Basic disposal/Irrigation System
- ✓ Disposal pumps to match application
- ✓ Suits New and Existing Premises
- ✓ Environmentally Friendly

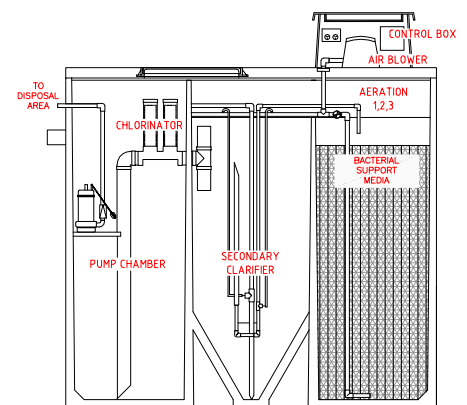
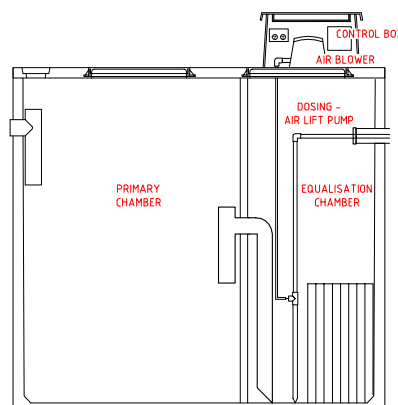
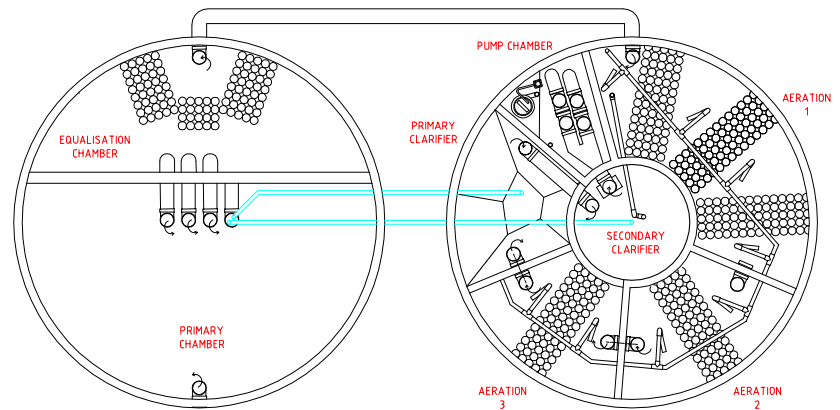

S5000 AWTS with Equalisation Tank

EXCAVATION DETAILS

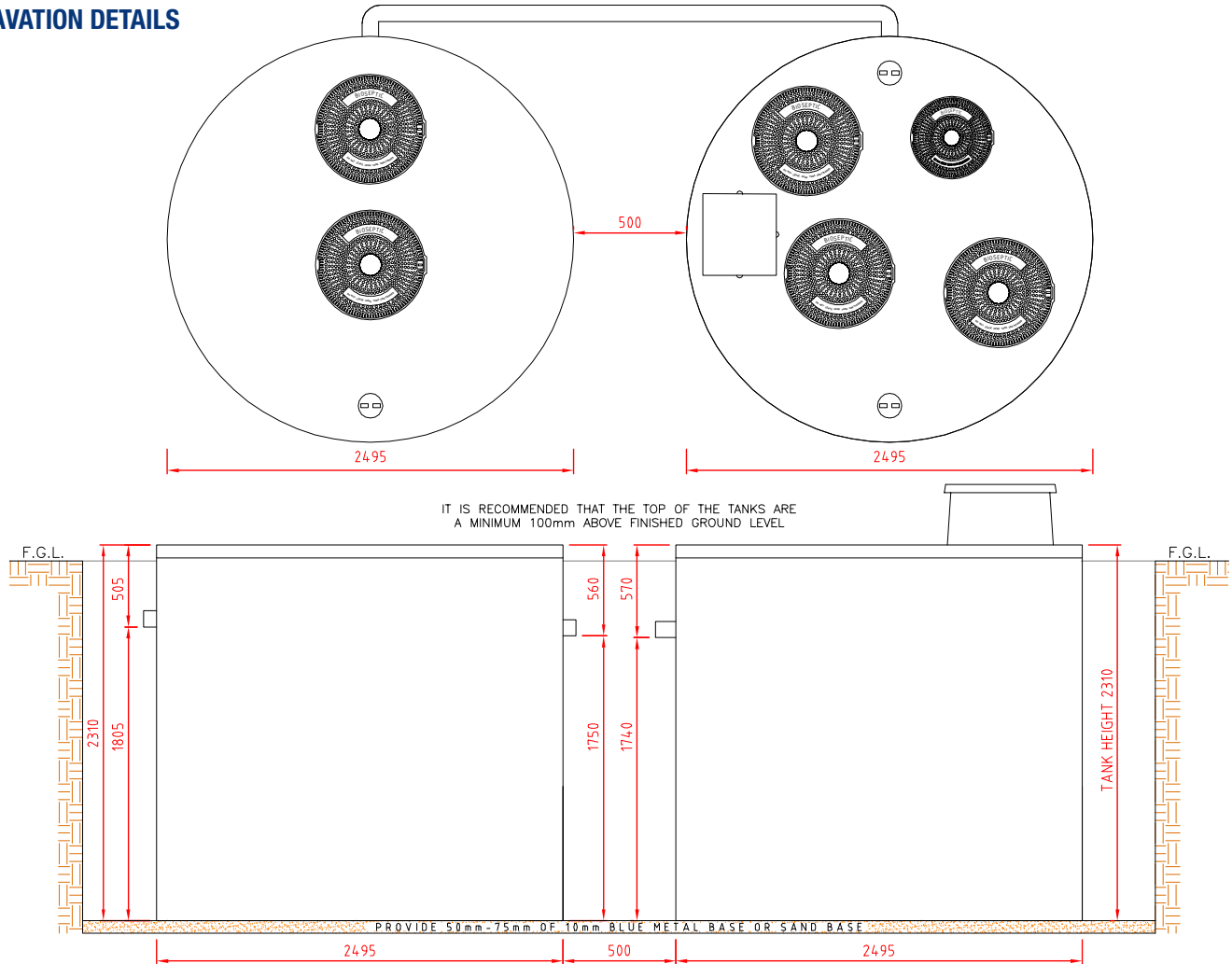

The S5000 was tested at the Jimboomba AWTS National test site and accredited to the Advanced Secondary Level of AS1546.3:2017. It achieved excellent results:

PARAMETER	AVERAGE CONCENTRATIONS	COMPLIANCE
Biochemical Oxygen Demand	BOD ₅ 1.37mg/L	100%
Suspended Solids	SS 3.07mg/L	100%
Pathogen Indicators	E. coli 0.37c.f.u/ 100mL	100%

TREATMENT CAPACITY

Treatment capacity varies with influent strength and flow pattern. BioSeptic can assist with designing the best system for any application.

OTHER BIOSEPTIC SEWAGE SYSTEMS

DOMESTIC MODELS	TANKS	TREATMENT CAPACITY FOR BALANCED DOMESTIC INFLUENT	USE
S-TEN	1	1500L/day	Single dwelling – 10 persons
Performa	2	1500L/day	Single dwelling – 10 persons
S2500	2	2500L/day	Larger dwelling
Commercial models			
S3500	2	3500L/day	Commercial premises
S5000	2	5000L/day	Commercial premises