

1100L Sewage Ejection Pump Station



1100Litre Sewage Ejection Pump Station



Weight 1500kg



To collect and transfer raw sewage or sullage water



Single or dual pumps with non-return and shut off valves to suit the site requirements:

- with high water audio/visual alarm



Retention feet to prevent flotation:

- When backfill is suitably placed and compacted in accordance with AS3798-2007 the pump station will have a resistance to floating of 3kN



LOCKABLE & LIGHTWEIGHT

composite resin access cover:

- Weigh only 8.5kg and easy to lift
- Lockable with removable turnkey
- Sealed to prevent the ingress of surface water
- Access turret can be extended to increase fall into tank



Manufactured from 40mpa wet cast concrete with fibre steel reinforcing



100mm concrete lid:

- Reinforced with F72 steel mesh
- Top load limit – 510kg



Installation:

- Top of tank lid to be 100mm above finished ground level
- Provide 75mm level bed of aggregate under tank

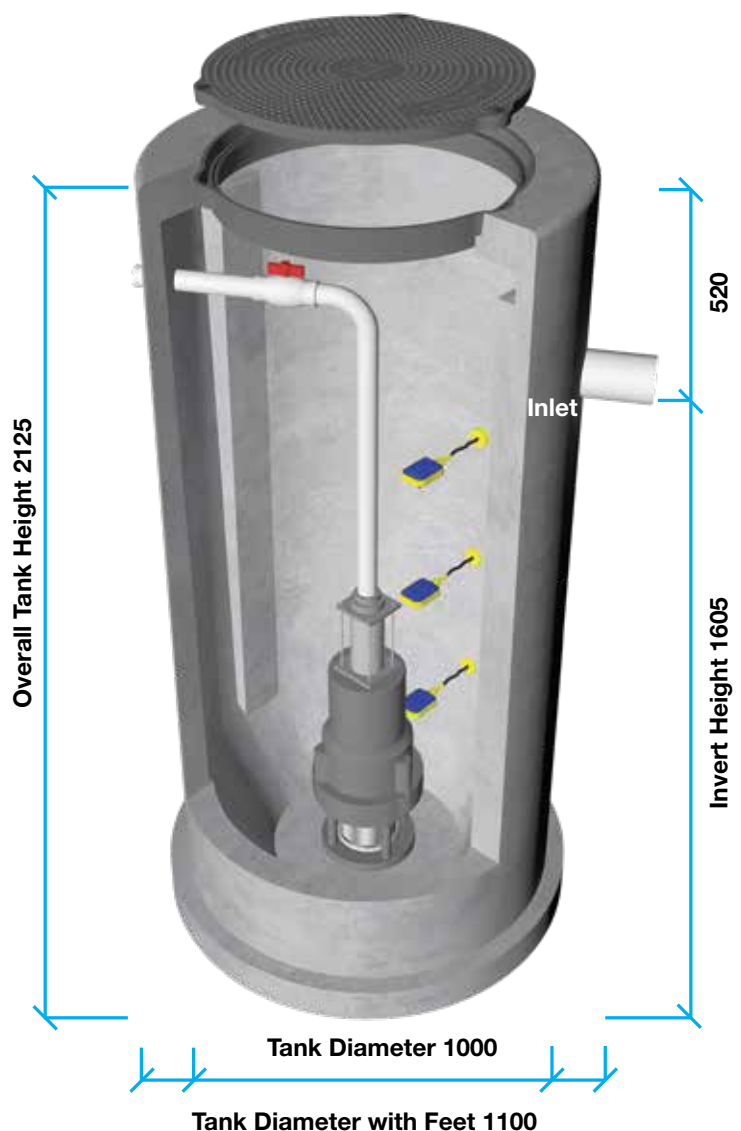

NSW Ministry of Health
Certificate of Accreditation
003-21556

67 Smeaton Grange Road,
Smeaton Grange, NSW 2567
EMAIL sales@bioseptic.com.au
ABN 95 056 461 226

BIOSEPTIC

PHONE 1300 658 111