



BioSeptic *Simply the Best!*

NSW HD
1546.3
Lic 2221
AWTS

PRODUCT GUIDE: JUMBO 3500 AWTS

DESCRIPTION

- Turn your wastewater into clear, odourless, safe water for irrigation of your gardens and lawns.
- Reliable, high quality, Australian built, all concrete treatment system.
- Used for larger developments with non-uniform wastewater generation rates.
- Backed up by the best customer service and after sales support.
- Designed to deal with high water loads over short periods of time.
- Used for larger homes and dual occupancies.

FEATURES

- 30 Year Warranty — Tanks and Insert
- 2 Year Warranty — Pumps and Blowers and all Original Electrical Components
- 5 Year Warranty—Internal pipe work
- Integrated Alarm System
- Chlorine Disinfection
- Two-tank Design
- 1st Year Servicing Free
- Includes Basic Irrigation System
- Choice of Pumps
- Suits New and Existing Buildings
- Environmentally Friendly
- Accredited by the NSW Health Dept.
- Testing revealed;
 - ⇒ 97% Reduction in Organic Waste
 - ⇒ 98% Reduction in Suspended Solids
 - ⇒ 99.99% Reduction of Faecal Coliforms

SPECIFICATIONS

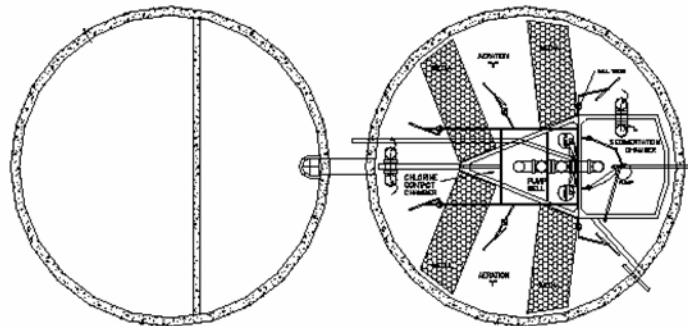

SEPTIC TANK

TREATMENT TANK

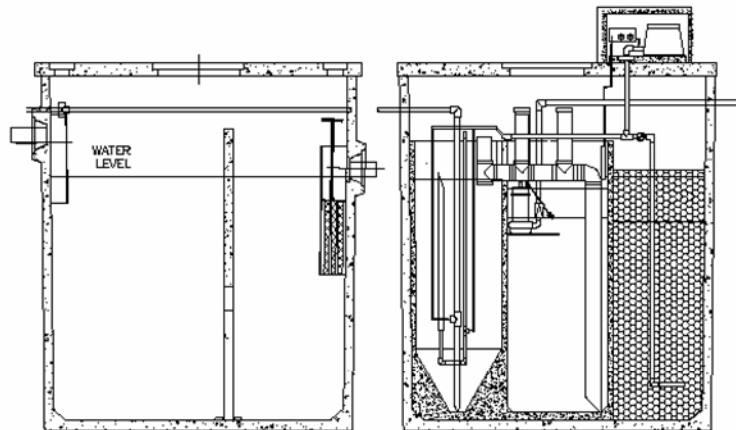

WHY WASTE WATER ?



SEWAGE SYSTEMS

CONTACT

BioSeptic Pty Ltd
 ABN 95 056 461 226
 Anzac Ave, Smeaton Grange, NSW 2567
 PO Box 3250, Narellan, NSW 2567

Ph: 1300 658 111
 Fax: (02) 4629 6655
 Email: sales@bioseptic.com.au
 Web: www.bioseptic.com.au

