



# BioSeptic

*Simply the Best!*



NSW HD  
GL Pt 3  
Lic 2221  
AWTS

## PRODUCT GUIDE: SEPTIC TANK 7000 AWTS

### DESCRIPTION

- 7000 litre baffled septic tank.
- Reliable, high quality, Australian built, all concrete tank.
- Used for domestic and industrial developments.
- Backed up by the best customer service and after sales support.
- Included, removable BioSeptic plastic outlet filter increases trench or bed life.
- Provides “primary” wastewater treatment suitable for trench, bed or mound type application systems.

### FEATURES

- 30 Year Warranty
- Included outlet filter
- Manhole access
- Can be installed by any licensed drainer or plumber
- 510kg top load limit
- No pumps or electrical requirements
- Suits New and Existing Buildings
- Precast concrete with integrated baffle
- Australian made and owned
- Very low maintenance requirements
- After sales service available
- NSW Health accredited
- Designed to AS/NZS1546.1 :1998

### SPECIFICATIONS

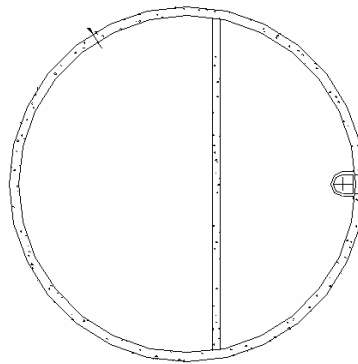

PLAN (Without lid)

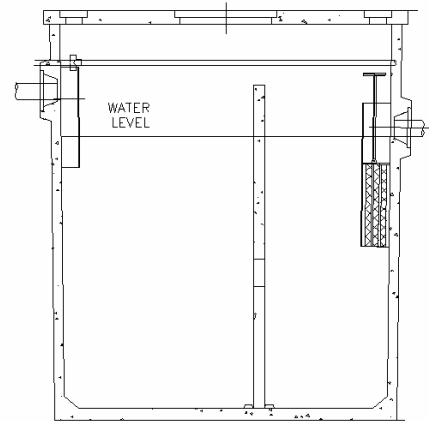

ELEVATION (with lid)

### WHY WASTE WATER ?



#### CONTACT

BioSeptic Pty Ltd  
ABN 95 056 461 226

Anzac Avenue,  
Smeaton Grange, NSW, 2567

PO Box 3250,  
Narellan, NSW, 2567

Ph: 1300 658 111

Fax: (02) 4629 6655

Email: [sales@bioseptic.com.au](mailto:sales@bioseptic.com.au)

Web: [www.bioseptic.com.au](http://www.bioseptic.com.au)